





TEMPEST**1000**WA

TEMPEST**1000**OPEN

TEMPEST**900**WA

TEMPEST**900**OPEN

TEMPEST**900**LUXE

TEMPEST**850**WA

TEMPEST**850**OPEN

TEMPEST**800**

TEMPEST**775**

TEMPEST**750**SPORT/LUXE

TEMPEST**700**

TEMPEST**650**

TEMPEST**600**

TEMPEST**570**

TEMPEST**530**

TEMPEST**480**

TEMPEST**430**





TEMPEST1000WA





TECHNICAL FEATURES

LENGTH O.A.	10,64 mt
BEAM O.A.	3,28 mt
TUBE DIAMETER	0,60 mt max
DRY WEIGHT (approx.)	3000 kg
MAX. PEOPLE ON BOARD	18
MAX. ENGINE POWER	700 HP (2 XL) <small>Max total engines weight 600 kg</small>
CERTIFICATION CE	B
TUBE	Neoprene - Hypalon Orca® 1670 dtex

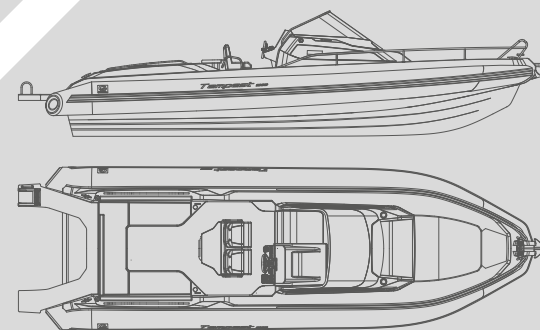

Design by: Cantieri Capelli's technical dept.

TEMPESTIOOWWA





TEMPESTI0000OPEN





TECHNICAL FEATURES

LENGTH O.A.	10,10 mt
BEAM O.A.	3,31 mt
TUBE DIAMETER	0,65 mt max
DRY WEIGHT (approx.)	2450 kg
MAX. PEOPLE ON BOARD	22
MAX. ENGINE POWER	600 HP (2 XL)
CERTIFICATION CE	B
TUBE	Neoprene - Hypalon Orca® 1670 dtex

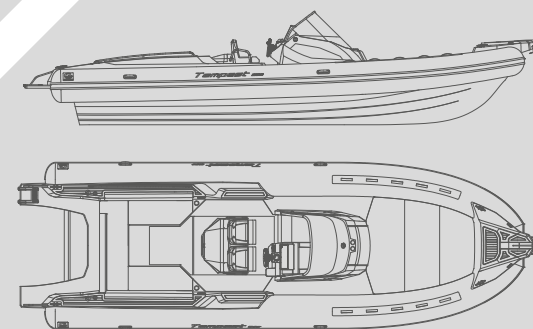

Design by: Cantieri Capelli's technical dept. in partnership with Roberto Curtò Design

TEMPEST1000OPEN





TEMPEST 900WA





TECHNICAL FEATURES

LENGTH O.A.	9,50 mt
BEAM O.A.	3,30 mt
TUBE DIAMETER	0,65 mt max
DRY WEIGHT (approx.)	2200 kg
MAX. PEOPLE ON BOARD	18
MAX. ENGINE POWER	500 HP (1 U / 2 XL)
CERTIFICATION CE	B
TUBE	Neoprene - Hypalon Orca® 1670 dtex

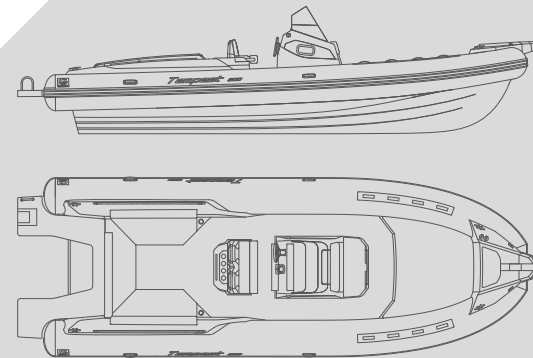

TEMPEST 900WA





TEMPEST9000OPEN





TECHNICAL FEATURES

LENGTH O.A.	9,60 mt
BEAM O.A.	3,24 mt
TUBE DIAMETER	0,65 mt max
DRY WEIGHT (approx.)	2100 kg
MAX. PEOPLE ON BOARD	18
MAX. ENGINE POWER	500 HP (1 U / 2 XL)
CERTIFICATION CE	B
TUBE	Neoprene - Hypalon Orca® 1670 dtex

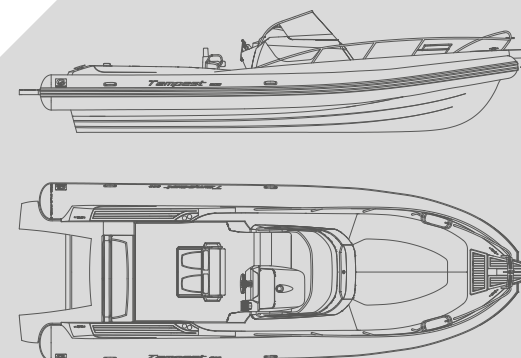

TEMPEST 900 OPEN





TECHNICAL FEATURES

LENGTH O.A.	9,62 mt
BEAM O.A.	3,25 mt
TUBE DIAMETER	0,65 mt max
DRY WEIGHT (approx.)	2100 kg
MAX. PEOPLE ON BOARD	20
MAX. ENGINE POWER	500 HP (1 U / 2 XL)
CERTIFICATION CE	B
TUBE	Neoprene - Hypalon Orca® 1670 dtex

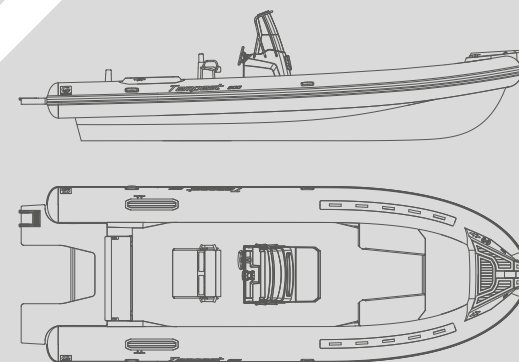

TEMPEST900LUXE



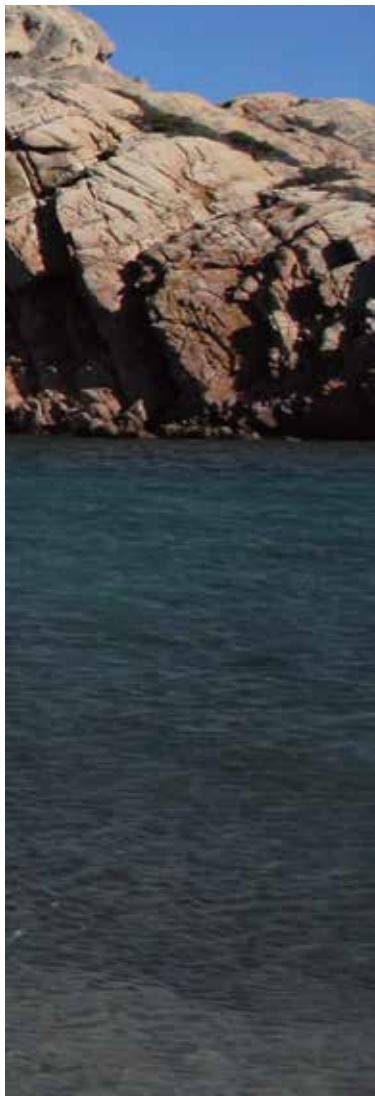

TECHNICAL FEATURES

LENGTH O.A.	8,85 mt
BEAM O.A.	3,26 mt
TUBE DIAMETER	0,60 mt max
DRY WEIGHT (approx.)	2200 kg
MAX. PEOPLE ON BOARD	16
MAX. ENGINE POWER	450 HP (1 U / 2 XL)
CERTIFICATION CE	B
TUBE	Neoprene - Hypalon Orca® 1670 dtex

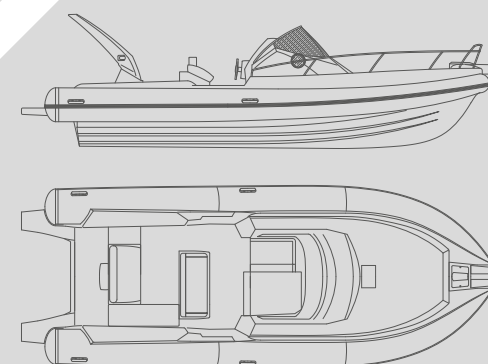

Design by Roberto Curtò

TEMPEST 850WA





TECHNICAL FEATURES

LENGTH O.A.	8,50 mt
BEAM O.A.	3,24 mt
TUBE DIAMETER	0,65 mt max
DRY WEIGHT (approx.)	1900 kg
MAX. PEOPLE ON BOARD	16
MAX. ENGINE POWER	400 HP (1 U / 2 XL)
CERTIFICATION CE	B
TUBE	Neoprene - Hypalon Orca® 1670 dtex

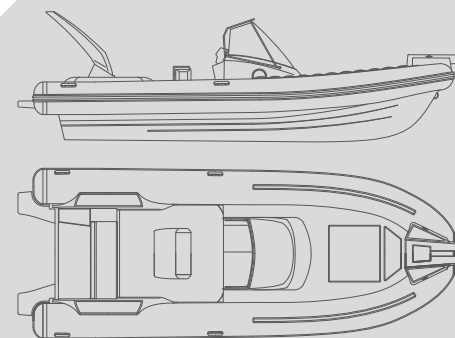

TEMPEST 850 OPEN





TECHNICAL FEATURES

LENGTH O.A.	7,91 mt
BEAM O.A.	3,06 mt
TUBE DIAMETER	0,64 mt max
DRY WEIGHT (approx.)	1500 kg
MAX. PEOPLE ON BOARD	15/18
MAX. ENGINE POWER	300 HP (1 XL)
CERTIFICATION CE	B/C
TUBE	Neoprene - Hypalon Orca® 1670 dtex

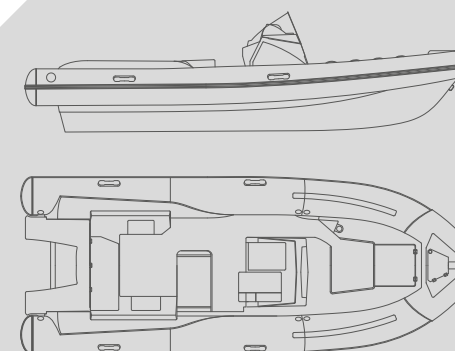

TEMPEST800





TECHNICAL FEATURES

LENGTH O.A.	7,75 mt
BEAM O.A.	2,99 mt
TUBE DIAMETER	0,65 mt max
DRY WEIGHT (approx.)	1350 kg
MAX. PEOPLE ON BOARD	12/22
MAX. ENGINE POWER	250 HP (1 XL)
CERTIFICATION CE	B/C
TUBE	Neoprene - Hypalon Orca® 1670 dtex

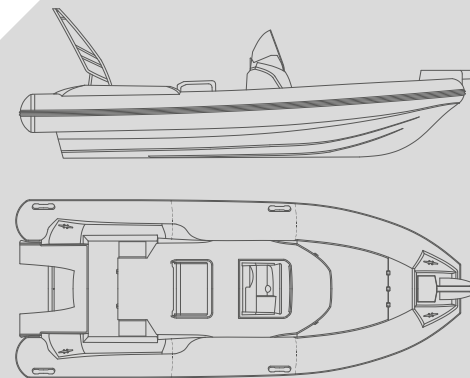

TEMPEST775



TEMPEST SPORT 750

TECHNICAL FEATURES

LENGTH O.A.	7,48 mt
BEAM O.A.	2,98 mt
TUBE DIAMETER	0,65 mt max
DRY WEIGHT (approx.)	1250 kg
MAX. PEOPLE ON BOARD	20
MAX. ENGINE POWER	250 HP (1 XL)
CERTIFICATION CE	C
TUBE	Neoprene - Hypalon Orca® 1670 dtex

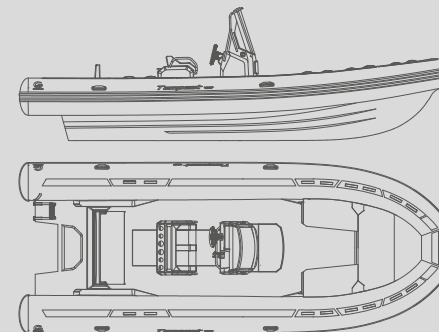



TECHNICAL FEATURES

LENGTH O.A.	7,65 mt
BEAM O.A.	2,98 mt
TUBE DIAMETER	0,65 mt max
DRY WEIGHT (approx.)	1300 kg
MAX. PEOPLE ON BOARD	20
MAX. ENGINE POWER	250 HP (1 XL)
CERTIFICATION CE	C
TUBE	Neoprene - Hypalon Orca® 1670 dtex

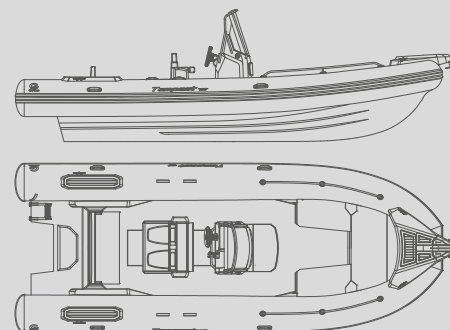

TEMPEST LUXE
750



TEMPEST 700

TECHNICAL FEATURES

LENGTH O.A.	7,35 mt
BEAM O.A.	2,86 mt
TUBE DIAMETER	0,58 mt max
DRY WEIGHT (approx.)	1050 kg
MAX. PEOPLE ON BOARD	16
MAX. ENGINE POWER	225 HP (1 XL)
CERTIFICATION CE	C
TUBE	Neoprene - Hypalon Orca® 1670 dtex

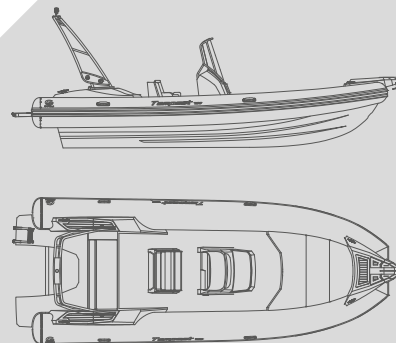



TECHNICAL FEATURES

LENGTH O.A.	6,55 mt
BEAM O.A.	2,66 mt
TUBE DIAMETER	0,56 mt max
DRY WEIGHT (approx.)	800 kg
MAX. PEOPLE ON BOARD	12
MAX. ENGINE POWER	200 HP (1XL)
CERTIFICATION CE	C
TUBE	Neoprene - Hypalon Orca® 1670 dtex

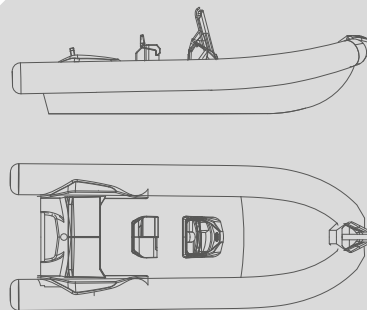

TEMPEST
650





TEMPEST 600

TECHNICAL FEATURES

LENGTH O.A.	5,92 mt
BEAM O.A.	2,49 mt
TUBE DIAMETER	0,55 mt max
DRY WEIGHT (approx.)	600 kg
MAX. PEOPLE ON BOARD	12
MAX. ENGINE POWER	140 HP (1XL)
CERTIFICATION CE	C
TUBE	Neoprene - Hypalon Orca® 1670 dtex

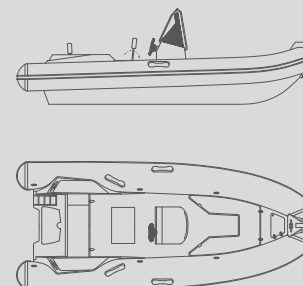



TECHNICAL FEATURES

LENGTH O.A.	5,60 mt
BEAM O.A.	2,62 mt
TUBE DIAMETER	0,56 mt max
DRY WEIGHT (approx.)	551 kg
MAX. PEOPLE ON BOARD	12
MAX. ENGINE POWER	135 HP (1L)
CERTIFICATION CE	C
TUBE	Neoprene - Hypalon Orca® 1100 dtex

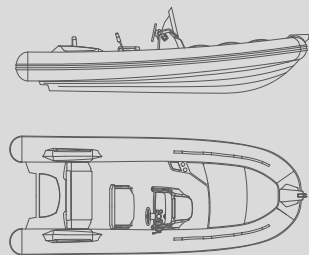

Design by: Paolo Ferragni

TEMPEST
570





TEMPEST 530

TECHNICAL FEATURES

LENGTH O.A.	5,35 mt
BEAM O.A.	2,26 mt
TUBE DIAMETER	0,50 mt max
DRY WEIGHT (approx.)	450 kg
MAX. PEOPLE ON BOARD	9
MAX. ENGINE POWER	110 HP (1L)
CERTIFICATION CE	C
TUBE	Neoprene - Hypalon Orca® 1100 dtex

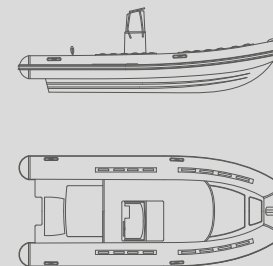



TECHNICAL FEATURES

LENGTH O.A.	4,82 mt
BEAM O.A.	2,30 mt
TUBE DIAMETER	0,50 mt max
DRY WEIGHT (approx.)	500 kg
MAX. PEOPLE ON BOARD	7
MAX. ENGINE POWER	80 HP (1L)
CERTIFICATION CE	C
TUBE	Neoprene - Hypalon Orca® 1100 dtex

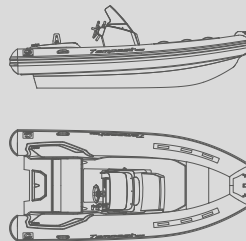

TEMPEST
480





TEMPEST 430

TECHNICAL FEATURES

LENGTH O.A.	4,22 mt
BEAM O.A.	2,02 mt
TUBE DIAMETER	0,45 mt max
DRY WEIGHT (approx.)	300 kg
MAX. PEOPLE ON BOARD	6
MAX. ENGINE POWER	40 HP (1L)
CERTIFICATION CE	C
TUBE	Neoprene - Hypalon Orca® 1100 dtex

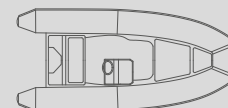

DOTAZIONI - EQUIPMENT

1000 WA 1000 OPEN 900 WA 900 OPEN 900 LUXE 850 WA 850 OPEN 800 775 750 SPORT 750 LUXE 700 OPEN 650 600 570 530 480 430

■ Standard ● Optional

Allestim. cabina con WC marino e serbatoio acque nere Cabin set-up with marine toilet and septic tank				●															
Asta da sci - Ski bar	●	●	●	●	●	●	●	●	●	●	●	●	●	●	● ¹	●			
Bitta ormeggio prua c/corrimano - Bow mooring cleat w/handrail										●									
Bitte ormeggio poppa (coppia) - Stern mooring cleat (pair)					●					●	●								
Copri-divano di poppa - Cover for stern bench	●																		
Copri-consolle - Console cover	●	●	●	●	●	●	●	●	●			●	●	●	●	●	●	●	●
Copri-panca - Bench cover												●	●	●	●	●	●	●	●
Cuscini di prua - Fore sunbathing cushions	■	■	■	■ ²	■ ³	■	■	■	■	■ ³	■ ³	■	■	●	●	●	●	●	●
Doccia - Shower	■	■	■	■	■	■	■	■	■	●	■	●	●	●	●	●			
	lt.94	lt.94	lt.60	lt.94	lt.94	lt.70	lt.60	lt.67	lt.67	lt.60	lt.60	lt.45	lt.67	lt.45	lt.45	lt.45			
Fornello - Cooker				● ^{PORTABLE}				● ^{PORTABLE}	● ^{PORTABLE}										
Frigorifero - Refrigerator	■ ⁴ lt.65	■ lt.65	■ lt.49	■ lt.65	■ lt.49	■ lt.49	■ lt.49	■ lt.49	■ lt.49	■ lt.49	■ lt.30								
Gonfiatore - Inflating pump	■ ELECTRIC	■ ELECTRIC	■ ELECTRIC	■ ELECTRIC	■ ELECTRIC	■ ELECTRIC	■ ELECTRIC	■ ELECTRIC	■ ELECTRIC	■	■	■	■	■	■	■	■	■	■
Impianto 220V - Dockside current tap 220V	●	●	●	●		●	●												
Luci di navigazione - Navigation lights	■	■	■	■	■	■	■	■	■	■	■	■	■	● ^{ON A-FRAME}	● ^{ON A-FRAME}	● ^{ON ARCH}	● ^{ON A-FRAME}		
Plance poppa - Stern platforms	■	■	■	■	■	■	■	■	■	■	■	■	■	■	■	■	■	■	■
Musone prua VTR - GRP Bow roller	■	■	■	■	■	■	■	■	■	●	■	■	■	■	■	■	■	■	■
Panca guida leaning post - Leaning post			■		■	■	■	■	■	■	■	■	■	■	●				
Panca guida VTR - GRP Steering bench	■	■		■								■		■	■	■	■	■	■
Pannello elettrico - Electric panel	■	■	■	■	■	■	■	■	■	■	■	■	■	■	■	■	■	■	■
Parabrezza - Windscreen	■	■	■	■	■	■	■	■	■	■	■	■	■	■	■	■	■	■	■
Pompa sentina - Bilge pump	■ AUTOMATIC	■ AUTOMATIC	■ AUTOMATIC	■ AUTOMATIC	■ AUTOMATIC	■ AUTOMATIC	■ AUTOMATIC	■ AUTOMATIC	■ AUTOMATIC	■ AUTOMATIC	■ AUTOMATIC	■ AUTOMATIC	■ AUTOMATIC	■ AUTOMATIC	■ AUTOMATIC	■ AUTOMATIC	■ AUTOMATIC	■ AUTOMATIC	■ AUTOMATIC
Prendisole addiz. Poppa - Add. aft sunbathing kit	■	■	●	●		●	●	●	●			●	●	●					
Pulpito inox - Stainless steel pulpit	■		■			■	●			●	■								
Radio	■	■	●	●	●	●	●	●	●	●	●	●	●	●	●	●	●	●	●
Rivest. flexiteek delfiniera - Flexiteek covering on bow roller		■	■	■	■	■	■	■	■	■	■	■	■	■	■	■	■	■	■
Rivest. flexiteek trincarini - Flexiteek covering on stringers	■									■	■	■	■	●	●	●			●
Rivest. flexiteek pozzetto - Flexiteek covering on cockpit	● ⁵	● ⁵	● ⁵	● ⁵	● ⁵	● ⁵	●	● ⁵	● ⁵	● ⁵	● ⁵	● ⁵	●	●	●				
Roll-bar inox - Stainless steel A-frame					●			●	■	●	●	■	●	●	●	●			
Roll-bar VTR - GRP A-frame	● ⁶	● ⁶	●	● ⁶		■	■	●	●										
Scaletta - Ladder	■	■	■	■	■	■	■	■	■	■	■	■	■	■	■	■	■	■	●
Serbatoio benzina - Fuel tank (Circa - Approx)	■ lt.550	■ lt.390	■ lt.350	■ lt.390	■ lt.390	■ lt.325	■ lt.390	■ lt.300	■ lt.250	■ lt.355	■ lt.355	■ lt.205	■ lt.205	■ lt.130	■ lt.86	■ lt.86	■ lt.86		
Soft-top inox - SS soft-top		●	●		●					●	●								
Hard-top VTR avorio / Ivory GRP Hard-top	●	●	●	●						● ⁷	●								
Tavolo - Table	■ ⁸	■ ⁸	■	■ ⁸	■	■	■	■	■	■	■	■	■	■	■	■	■	■	■
Telo ricovero - Boat storage cover			●		●	●	●	●	●		●	●	●	●	●	●	●	●	●
Tendalino - Sunshade arch	●	●	●	●	●	●	●	●	●	●	●	●	●	●	●	●	●	●	●
Timoneria idraulica - Hydraulic steering	■	■	■	■	■	■	■	■	■	■	■	■	■	●					
Trincarini VTR porta bitta (coppia) - GRP stringers for cleat (pair)					■					●	■								
Vano add. prua VTR con cuscini - Bow GRP add. locker w/cushions					● ⁹														
Verricello elettrico - Electric winch	■	■	■	■	■	■	■	■	●	●	● ¹⁰	●	●						
WC marino con serbatoio acque nere - Marine toilet with septic tank	■	■	■	● ¹¹		■	■	■											

¹ Disponibile anche OPT arco sci nautico; Available also OPT water ski arch
² Solo puntale, completamento prua OPT; Bow cushion only, additional front sundeck OPT
³ Comprende prolungamento con pagliolo e cuscino addizionale; Includes sunbed extension with wooden support and cushion
⁴ Disponibile OPT frigorifero a cassetto lt. 30 in cabina; Available OPT cabin draw fridge lt. 30
⁵ Include rivestimento su plancia poppa (per TE 1000WA comprende rivestimento prua); Includes covering on stern platform (bow planking included for TE 1000WA)
⁶ OPT installabile solo in fase produzione, non in post-vendita; OPT that can be installed only in production phase, not in post-production
⁷ Disponibile OPT mancorrenti Hard-top (coppia). Hard-top VTR grigio artic; Available OPT Hard-top SS bars (pair). Hard-top in artic grey GRP
⁸ STD per TE 1000WA/OPEN tavolo abbattibile con cuscino addizionale di poppa, OPT per TE 900OPEN; STD on TE 1000WA/OPEN pull-down table with additional sundeck cushion, OPT on TE 900OPEN
⁹ OPT installabile solo in fase produzione, non in post-vendita. Rimozione panche prua e pagliolo STD; OPT that can be installed only in production phase, not in post-production. STD fronte benches and add. support to be removed.
¹⁰ Include musone VTR; Includes GRP dolphins strinker
¹¹ Incluso nell'allestimento cabina OPT; Included in the cabin set-up OPT

N.B: Parabordo con decoro nocciola su unità prodotte fino alla stagione 2018/2019.
 Parabordo con decoro off-white in variazione nel corso della stagione 2019/2020.
 PLEASE NOTE: Fender with light brown accent on models produced until season 2018/2019.
 Fender with off-white accent changing during season 2019/2020.

Tutte le caratteristiche relative all'intera gamma non sono vincolanti. Cantieri Capelli si riserva il diritto di modificarle senza preavviso. Le imbarcazioni raffigurate possono essere equipaggiate con accessori optional.
 All features and data concerning our whole production are not binding. The shipyard Capelli reserves the right to modify them without advance notice. The boats shown can be equipped with additional options.



Cantieri Capelli S.r.l.

Via delle industrie, 19 - 26020 Spinadesco - Cremona (Italy)

Tel. +39 0372 491399

E-mail: info@cantiericapelli.it - Web: www.cantiericapelli.it

